

# DVD 2™ WIRELESS REMOTE FOR PLAYSTATION®2

ENGLISH

Thank you for purchasing the Mad Catz DVD 2 Wireless Remote. The Mad Catz DVD 2 is the best way to control the powerful DVD features of the PlayStation 2 computer entertainment system. Navigate through menus, special DVD add-on footage, director's cuts and theatrical trailers - all from the comfort of your couch. Designed with the industry standard Infrared technology, the DVD remote allows seamless wireless control of your PlayStation 2. The Mad Catz DVD 2 will also function as a Universal Remote which will give you total control over your TV and VCR, bringing comfort and versatility to you in one convenient package.

Be sure to visit [www.madcatz.com](http://www.madcatz.com) to register your product and see new and exciting video game controllers for your every gaming need!

## SET-UP

### Connecting the Infrared receiver

1. Turn the PlayStation 2 power OFF.
2. Insert the infrared receiver into the number one controller port.
3. Connect PlayStation 2 controller to the Pass-Through port on the receiver.
4. Place game disk or DVD disk into the PlayStation 2.
5. Turn the power ON and begin viewing or playing.

### Battery Installation

1. Remove the battery cover of the Mad Catz DVD 2.
2. Insert two (2) AA batteries.
3. Replace the battery cover.

## LAYOUT

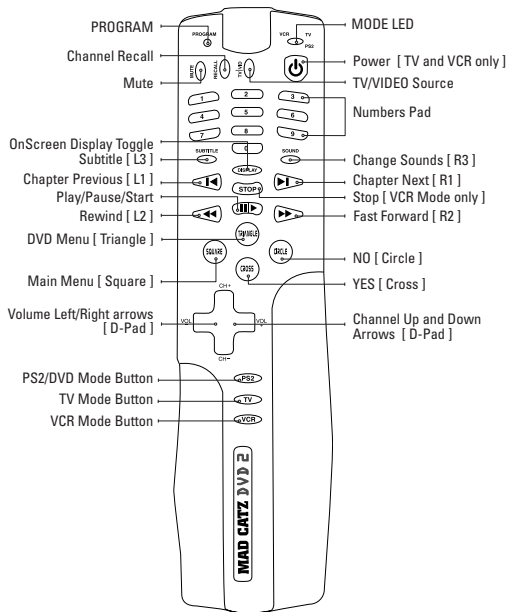

**Note:** If no buttons are pressed for forty-five (45) seconds the DVD 2 will enter power save mode. When a button is pressed in power save mode the controller will exit power save mode and execute the command of the button pressed.

**Note:** If the batteries are removed from the Universal Remote the TV and VCR codes are reset to default. Sony is the default TV and VCR.

## CONTROL MODES

The Mad Catz DVD 2 for the PlayStation 2 has three modes that will allow total control over your PlayStation 2, TV, and VCR. You change modes by pressing the Mode Button. The color of the mode LED indicates which mode you are in:

### PlayStation 2/DVD Mode - GREEN

To switch to PlayStation 2 (DVD) mode, press the PS2 button on the DVD 2. The Mad Catz DVD 2 is the best way to control for your PlayStation 2's DVD functionality. As an added feature the Mad Catz DVD 2 will also function as a standard PlayStation 2 controller and offers a convenient pass-through for a standard controller. The Mad Catz DVD 2 completely satisfies your entertainment needs in one convenient package.

### TV Mode - RED

Switch to TV mode by pressing the TV button on the DVD 2.

### Programming the TV mode

TV mode on the Mad Catz DVD 2 is the ideal way to control your TV viewing needs. By following the steps below you will be one step closer to comfort and satisfaction.

1. Push the TV button to switch to TV mode.
2. Locate your TV brand on the TV Code List.
3. Hold down Program button. If done correctly the mode LED will light GREEN.
4. While continuing to hold down Program button, enter the code for your TV. Do not enter the commands at the same time, make sure to enter them one at a time.

Example: To enter the code for a Toshiba brand TV, the first code "08."  
Press and hold the Program button (the MODE LED will flash in Green).

Press then release "0" button (the MODE LED will flash in Red).

Press then release "8" button (the MODE LED will flash in Amber, then go out).

Release the Program button.

5. If the first code you try does not work, try the others listed under your TV brand until the Universal Remote operates your TV properly.

### VCR Mode - AMBER

Switch to VCR mode by pressing the VCR button on the DVD 2.

### Programming the VCR mode

VCR mode on the Mad Catz DVD 2 is the final step for total control. Program your VCR by following the steps below and you will now have all your brand on the VCR Code List.

1. Push the VCR button to switch to VCR mode.
2. Locate your VCR brand on the VCR Code List.
3. Hold down Program button. If done correctly the mode LED will light GREEN.
4. While continuing to hold down Program button, enter the code for your VCR. Do not enter the code numbers at the same time, make sure to enter them one at a time.

Example: To enter the code for a Toshiba brand VCR, the code is "55."

Press and hold the Program button (the MODE LED will flash in Green)

Press then release "5" button (MODE LED will flash in Red).

Press then release "5" button (the MODE LED will flash in Amber, then go out).

Release the Program button.

5. If the first code does not work, try the others listed under your VCR brand until the Universal Remote operates your VCR properly.

## CAUTIONS

- DO NOT plug the infrared receiver into the game console while the power is ON.
- Precautions should be taken to prevent electrical shock.
- For indoor use only.
- Do not submerge in water.
- Not intended for children under 8 years.

**PROGRAMMING TABLE**

**VCR BRAND CODE SETTINGS**

Admiral 64	Daewoo 74, 93, 94	KEC 93	Philco 64, 69	Scott 65, 91	Wards 57, 59, 65, 68, 72, 78, 83
Adventura 74	Daytron 74	KLH 59	Portland 74	Sears 56, 57, 58, 72	White Westing- house 64, 63
Aiko 93	Dynatech 72	Lloyd's 72, 63	Profftronic 66	Shintom 59	XR-1000 59, 72
Aiwa 72	Emerex 75	Logik 59, 72	Proscan 83, 92	Shogun 66	Zenith 64, 63, 72, 76, 77, 79
America Action 93	Emerson 63, 64, 65, 69, 72, 91, 93, 94	MGA 66	Protac 59	Singer 59	
Asha 66	Fisher 57, 58	MGN Technology 66	Pulsar 79	Sony 72, 75, 76, 77	
Baumark 66	Fuji 76	MTC 72, 66	Quarter 56	Sylvania 72	
Bell & Howe 66	Funai 72	Magnasonic 93	Quartz 56	Symphonic 72	
Broksonic 64, 66, 91	GE 66, 83, 92	Magnavox 72, 79	RCA 66, 83, 92	TMK 63, 66	
CCE 59, 93	Garrard 66	Magnin 66	Radio Shack 72	Taac 72	
Capahrt 74	GO Video 68, 70	Memorex 56, 57, 64, 66, 72, 79	Realistic 56, 57, 72	Teknika 72	
Cineral 93	Gradiente 72	Multitech 59, 72	Ricoh 77	Thomas 77	
Citizen 52, 93	HK-Q 57	Nikon 77	Runco 79	Thomson 71	
Colt 59	Harley Davidson 72	Noblex 66	Samsung 66	Toshiba 65	
Craig 57, 59, 66, 67	Harwood 68	Optimus 66	Sanky 79	Television 66	
Curtis Mathes 83	Headquarter 56	Orion 64, 69, 91	Sansul 64, 67, 69, 72	Unitech 66	
Cybernex 66	Hitachi 72	Penney 58, 66	Sanyo 56, 57, 66	Videosonic 66	

**TELEVISION CODE LIST**

A-Mark 21	Carver 42	Funai 37, 17, 15	LG 05	Optimus 08, 19, 48	Samsung 01, 03, 05, 13, 12	TMK 05, 11, 12
Aec 01, 03, 21, 33	Celebrity 00	Futurtech 15	LXI 35, 42, 08, 09, 12	Optonica 32, 10	Tandy 32, 10	Tandyl 05, 11, 12
Admiral 20, 32	Cineral 14, 22	GE 02, 35, 36, 44, 32, 12, 38, 22	Logik 29	Orion 17, 16, 20	Sansul 20	Tatung 21, 44
Adventura 04	Citizen 03, 04, 05, 13, 14, 41, 49	Gibraller 30, 01, 03	Luxman 05	Panasonic 36, 44, 48	Sanyo 08, 47	Technics 36
Aiko 14	Chirtone 33	GoldStar 01, 03, 05, 12	MEI 33	Penney 21, 43, 01, 02, 03, 41, 35, 36, 05, 13, 09, 12	Scimitsu 01	Technic Ace 17
Alai 05	Concerto 05	Gradiente 31, 05	MGA 01, 03, 45, 12	Philco 01, 40, 03, 42, 53, 07, 20	Scotch 12	Techwood 21, 36, 05
Alaron 17	Contec 15, 33	Grumpy 17, 15	MTC 01, 03, 05, 13, 33	Philips 42	Scott 01, 12, 17, 15, 16	Teknika 28, 01, 41, 42, 05, 13, 14, 45, 17, 15
Ambassador 11	Craig 15	Halmark 11	Magnavox 40, 03, 42, 53, 17, 54,	Pioneer 19	Sears 35, 42, 05, 08, 09, 47, 37, 12, 17	Telafunken 05
America Action 15	Crosley 42	Harley Davidson 17	Majestic 29	Portland 01, 41, 14	Thomson 26, 27, 28	Toshiba 13, 08, 09
Anam 15	Crown 15, 41	Harman/ Kardon 42	Marantz 03, 42	Prism 36	Semp 09	Tosonic 33
Anam National 44	Curtis Mathes 03, 05, 07, 08, 13, 19, 22, 23, 29, 32, 35,	Harvard 15	Megatron 21, 07, 12	Proscan 35	Sharp 41, 32, 10	Vector Research 03
Archer 21	Daewoo 01, 41, 14, 22, 24, 25	Hitachi 29, 05, 07, 46	Memorex 08, 12, 48, 20	Shogun 01	Signature 29	Victor 31
Audiovox 14, 15, 21, 22, 24	Daytron 01	Infinity 42	Midland 30, 41, 35, 36	Proton 21, 12, 23	Simpson 54	Vidikron 42
Baysonic 15	Denon 07	Inteq 02	Minutz 02	Pulsar 30, 01	Sony 00	Vidtech 01, 12
Beisor 01	Dumont 30, 01	JBL 42	Mitsubishi 01, 32, 45, 12	Quasar 35, 44, 10, 48	RCA 43, 01, 35, 36, 06, 32, 39	Viking 04
Bell & Howell 01	Dwin 34, 52	JCB 00	Motorola 44, 32	Radio Shack 01, 03, 41, 35, 05, 08, 10, 12, 15	Multitech 21	Spectricon 21
Bradford 15	Electroband 00, 33	Janel 04	NAD 09, 19, 12	Squareview 37	White Westing- house 20, 24, 25	Supra-Alcay 01, 03
Brockwood 01	Emerson 01, 41, 08, 11, 12, 17, 15, 33, 16, 49, 38, 20, 24, 25	KEC 15	NEC 01, 03, 05	Starlite 15	Sylvania 46, 03, 42, 53	Yamaha 01, 03
Broksonic 16, 20, 21	CXC 15	KTV 03, 41, 15, 33, 49	NTC 14	Rhapsody 04	Supreme 00	Zenith 29, 30, 14, 20, 25
Candle 03, 04, 05	Envision 03	Kenwood 01, 03	Nikko 03, 14, 12	Runco 30, 03, 18	Sylvania 01, 15	Zonda 21
Carnivale 03	Fisher 08, 47	Kloss 04	Noshi 43	SSS 01, 15	Symphonic 37	
	Fujitsu 17, 50		Onwa 15	Sampo 03, 41		

## **TECHNICAL SUPPORT**

Mad Catz provides technical support for all of its products in a variety of ways.

**Online** - Check the Mad Catz Home Page at [www.madcatz.com](http://www.madcatz.com). There you will find up-to-the-minute solutions, tips, and information about all of our products.

Our comprehensive Tech Support area offers answers to nearly every question.

**E-mail** - You can send e-mail to our Support Technicians at [tech@madcatz.com](mailto:tech@madcatz.com).

In most cases, you will receive a reply within one business day.

**Telephone** - Technical Support is available from 9 A.M. to 5 P.M. pacific standard time, Monday through Friday (excluding holidays) at 1.800.659.2287 (U.S. only) or 1.619.258.6920 (outside U.S.).

**Fax** - Technical Support is available via fax at 1.619.258.6929.